

Feature:

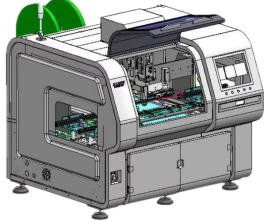

Unified Structure

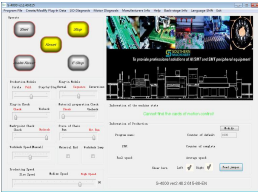

Unified Software



Super Cost-effective

S7020 Series Insertion Machine is designed and produced to insert components with special shape and dimension.

- You only need to **buy one** to realize a **full series of functions** (just switch the feeder and gripper).

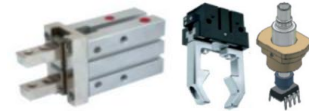
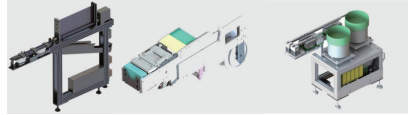

- Easy to operate, **one day** training can be fully mastered.

- The same function, the price is only **one-third** of the Universal machine.

Advantages of S7020 Series Insertion Machine

*One machine can replace at least **10** labors

*Price **30%** lower than other brands

*Faster speed, lower maintenance cost, **\$500** monthly spare parts maintenance other

*Simple operation, grasp with **1** day training



— **7x24 Worldwide Support**

— **Free Installation/ Training**

— **1 day lead-time (spare parts)**

— **1 Month customize solution**

S7020 Series Insertion Machine

S7020 Series Insertion Machine including:

1.S7020T **Terminal** Insertion machine (2 insertion heads and 2 reel feeders / or 2 bowl feeders)



2.S7020E **Eyelet** Insertion machine (2 insertion heads and 2 Bowl feeder)

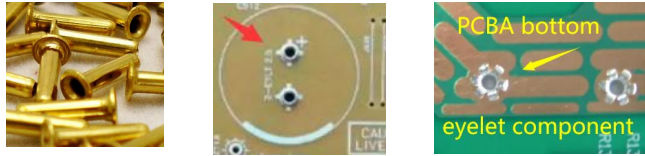

3.S7020P **PIN** Insertion machine (2 insertion heads and 2 reel feeder / or 2 Bowl feeder)

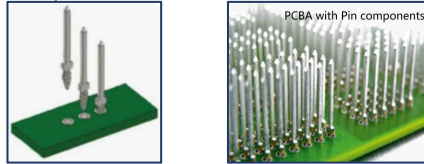

4.S7020S **Tact Switch** Insertion machine (2 insertion heads and 2 Bowl feeder)

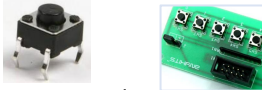

5.S7020F **Oddform** Insertion machine (2 insertion heads and 2 Bowl feeder /or 2 tube feeder)

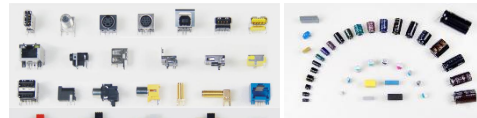

I'll never say tired,
just need regular
maintenance !



Structure

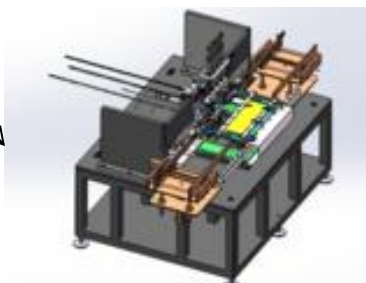
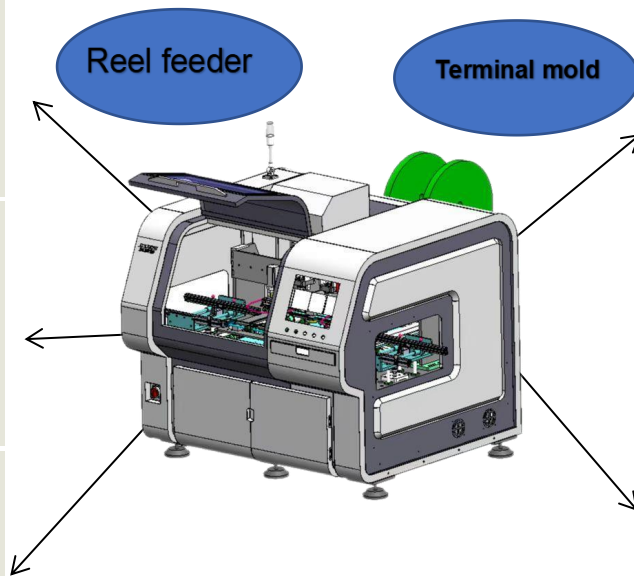
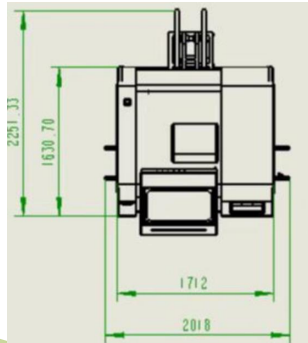
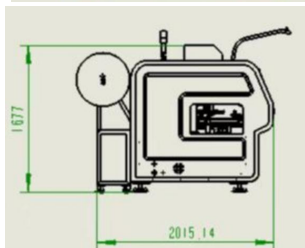

S7020 Series Insertion Machine

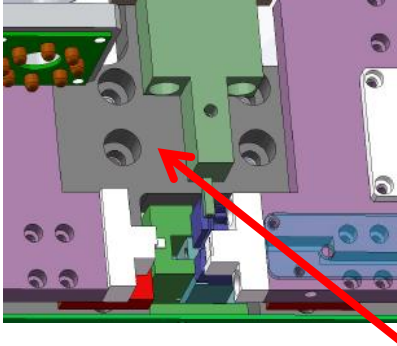

Insertion head

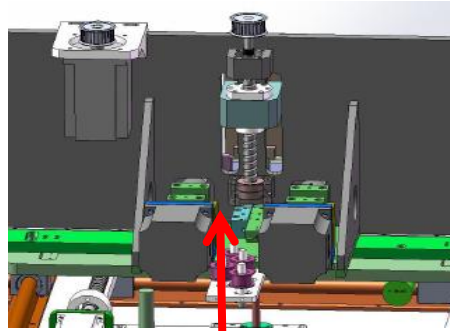

Feeder

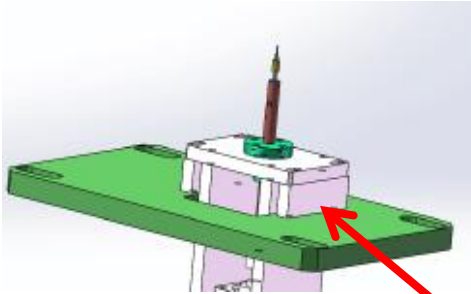

Clinching base(PCB support & miss check)

Vision programming



Machine Insertion Head ASSY

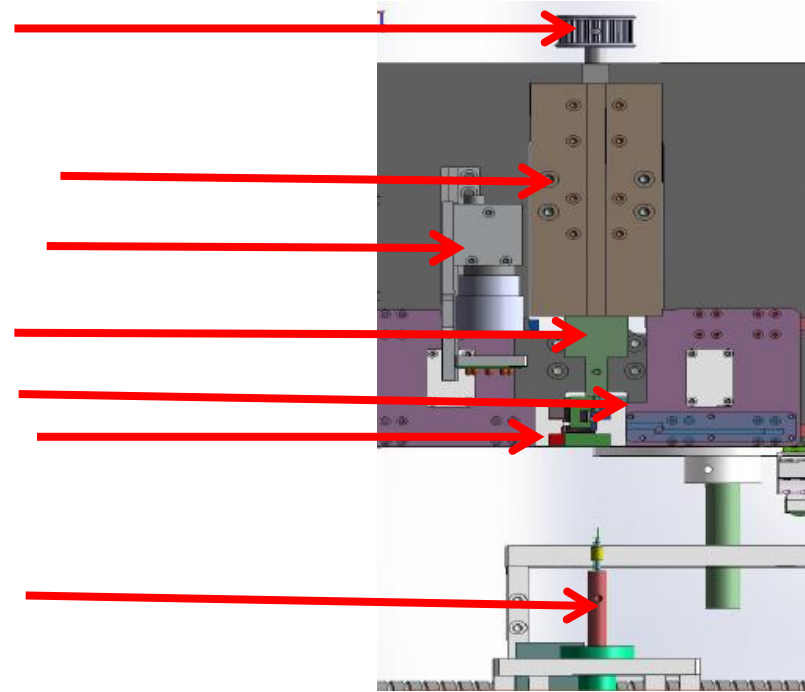
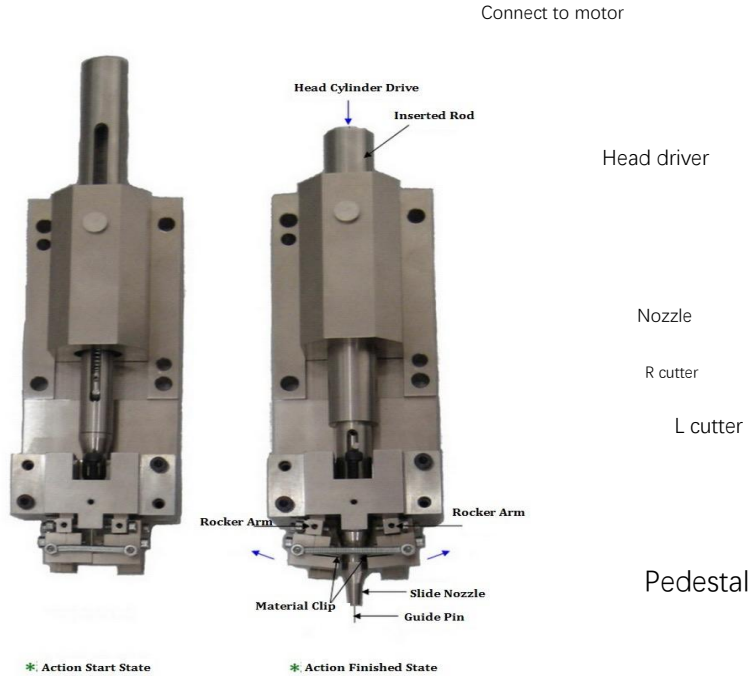

Feeding system

Design different feeders based on component package

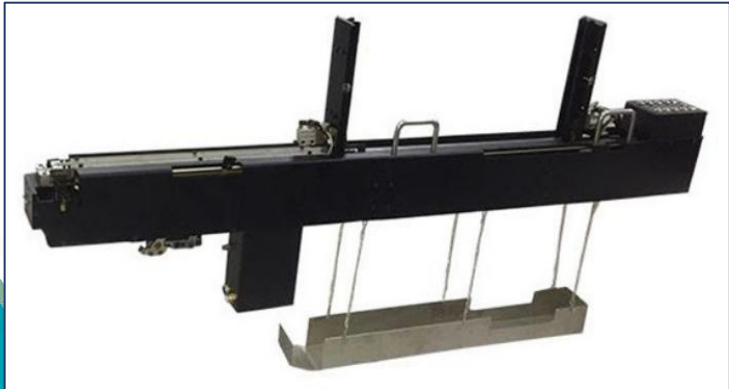
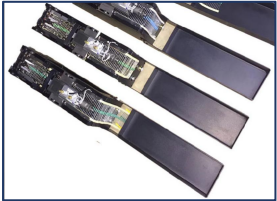
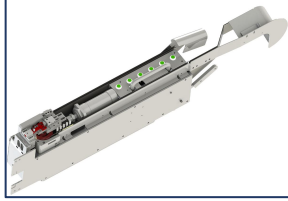
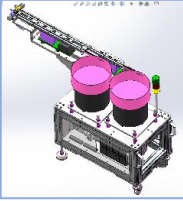

Clinching system

S7020 Series Insertion Machine

If the detection system detects that the insertion has completed successfully Go to the next step, if it is not completed, the machine will stop and report an error.) After that, the X-Y workbench will send the PCB completed by the insertion to the right track

Insertion Head Gripper/Nozzle



It is used to insert terminal components into a PCB automatically.



S7020T

- ▶ Applicable components: **Terminal**



- ▶ 2 insertion heads and 2 reel feeder/bowl feeder

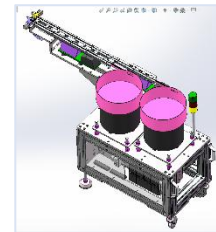
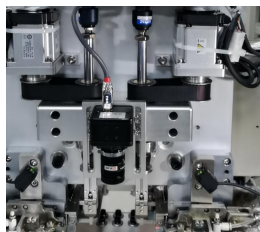

- ▶ Speed: **12000CPH**

Machine can be equipped with different feeders to transport Terminal Component in different package.

Reel Package

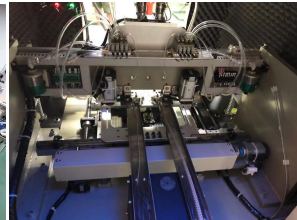
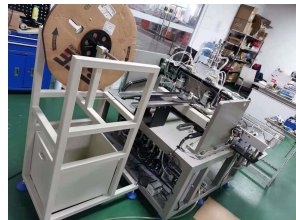

Reel Feeder

Bulk Package(loose)

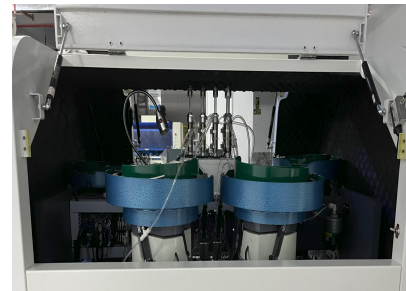
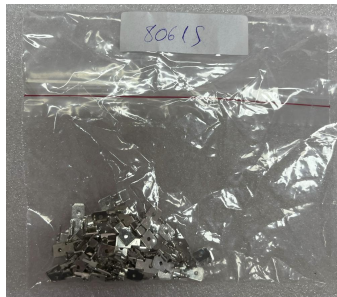

Bowl Feeder

S7020T Terminal Insertion Machine

Machine main sub-assembly

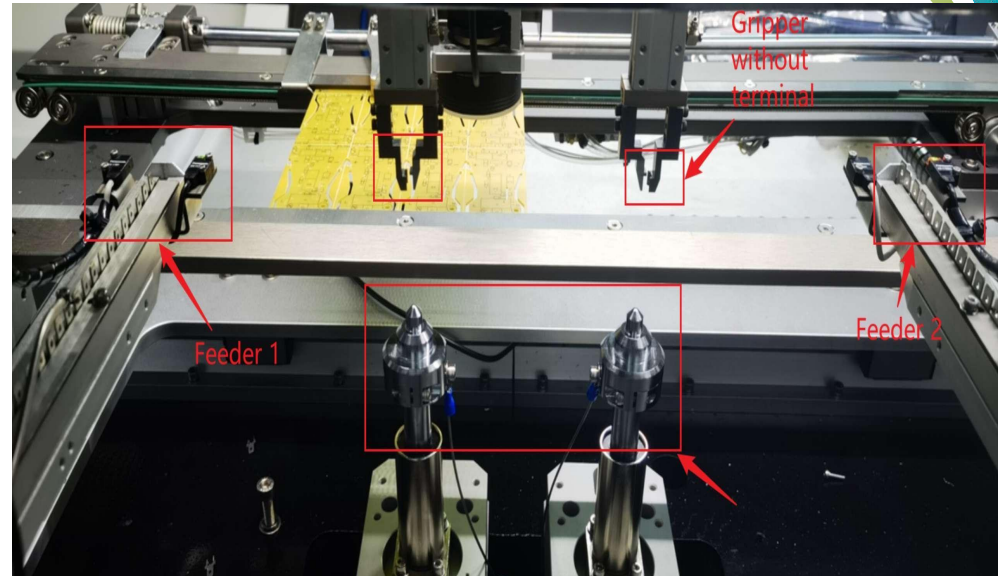
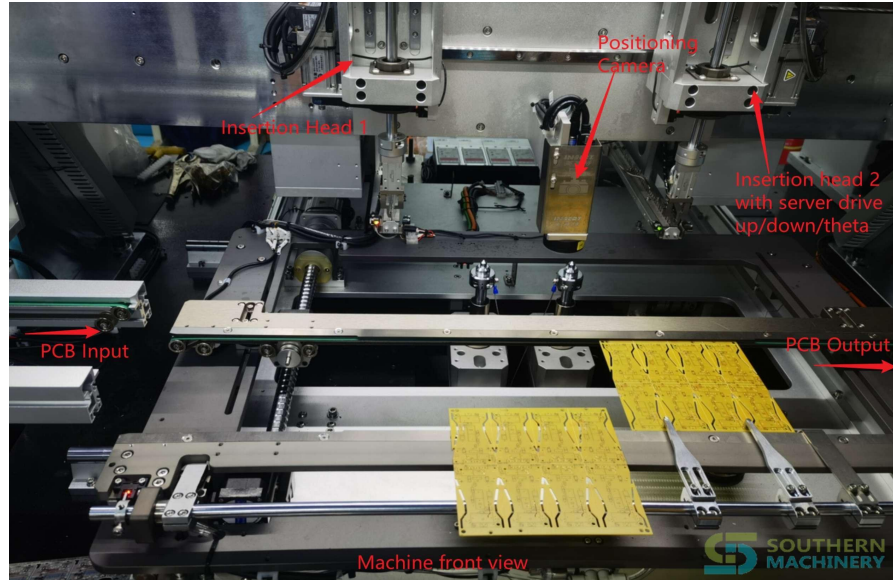

S7020T Terminal Insertion Machine

Machine main sub-assembly

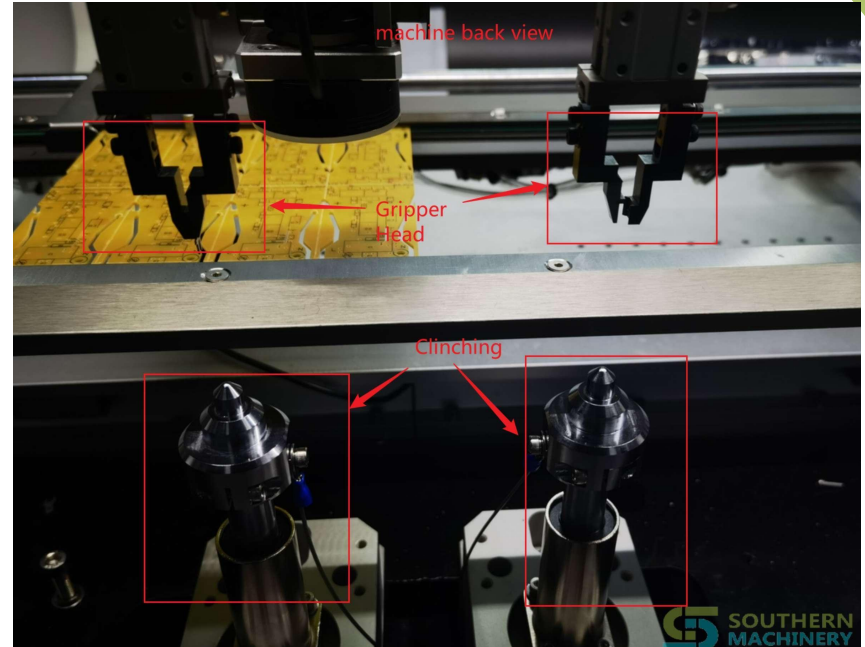

Insertion processing

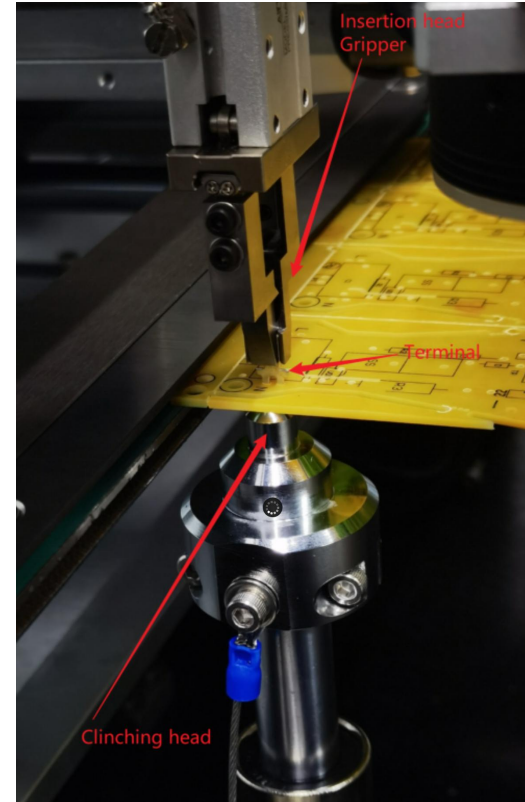
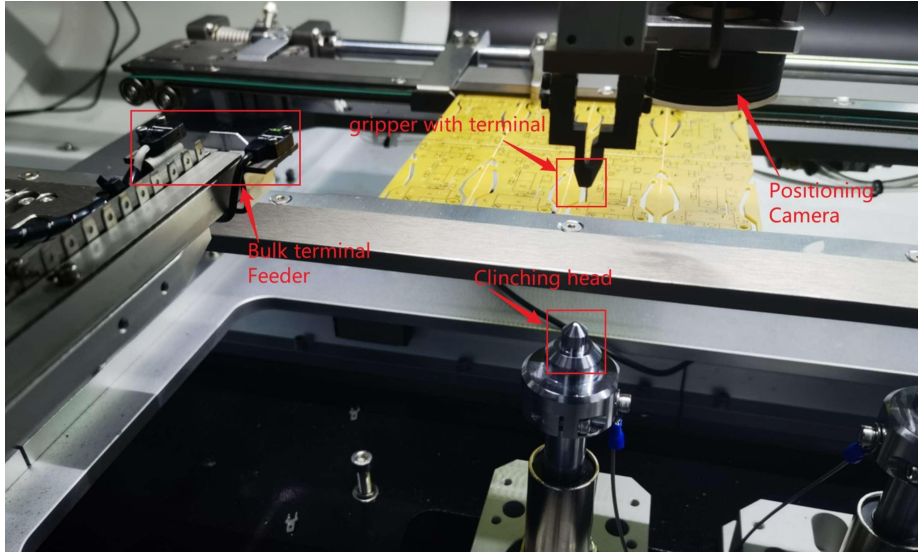

S7020T Terminal Insertion Machine

After Insertion

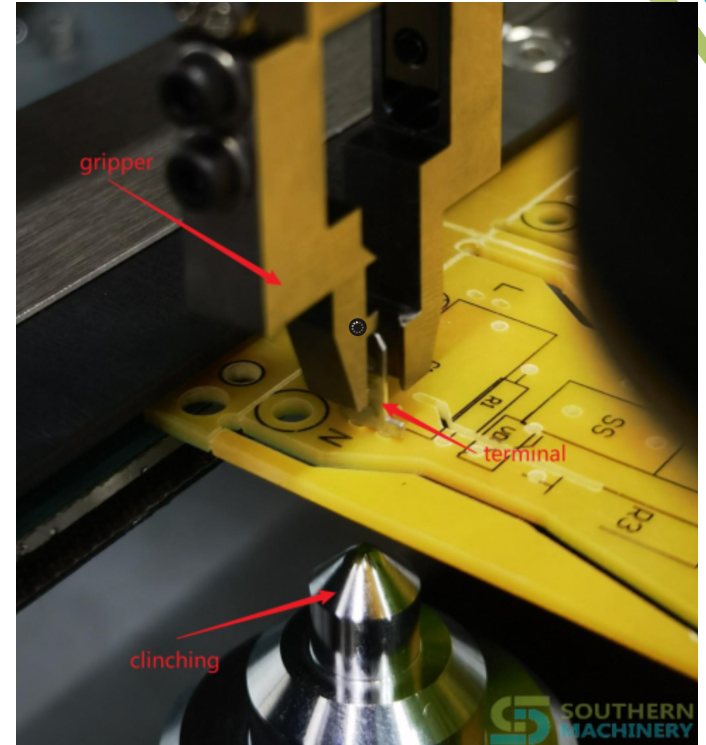
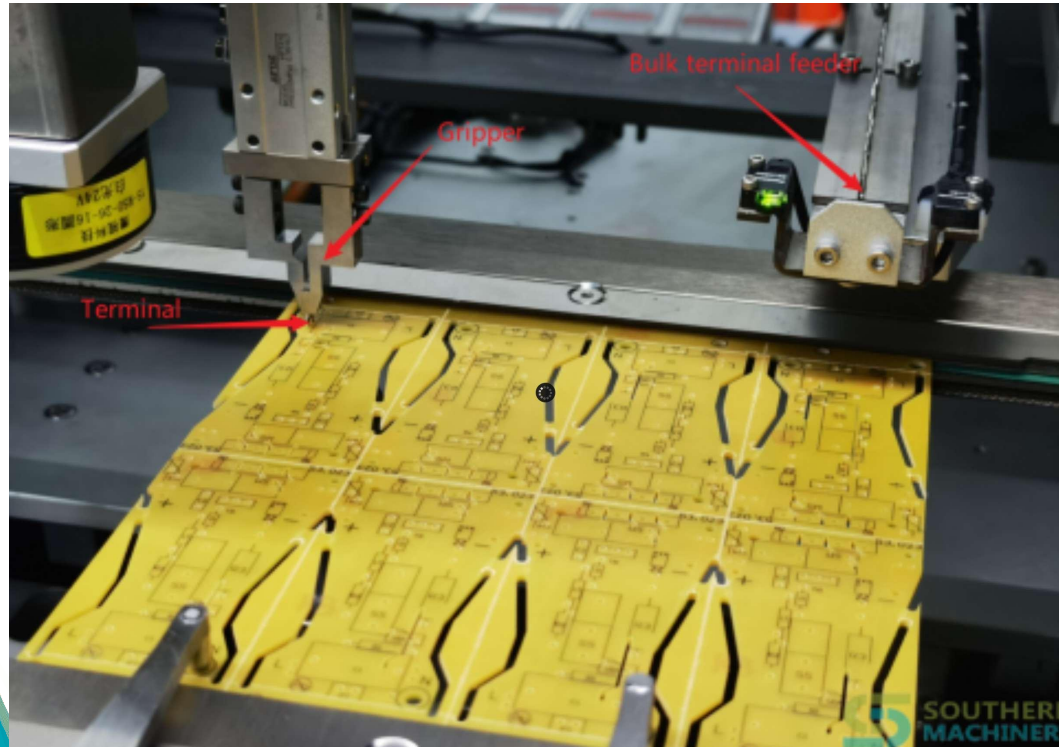

S7020T Terminal Insertion Machine

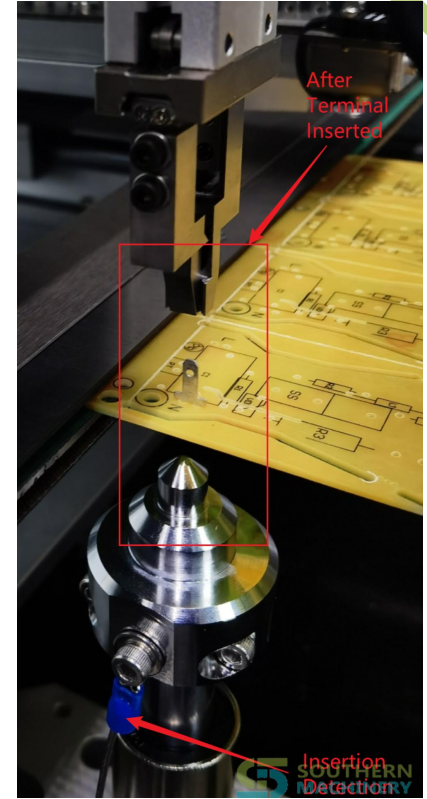
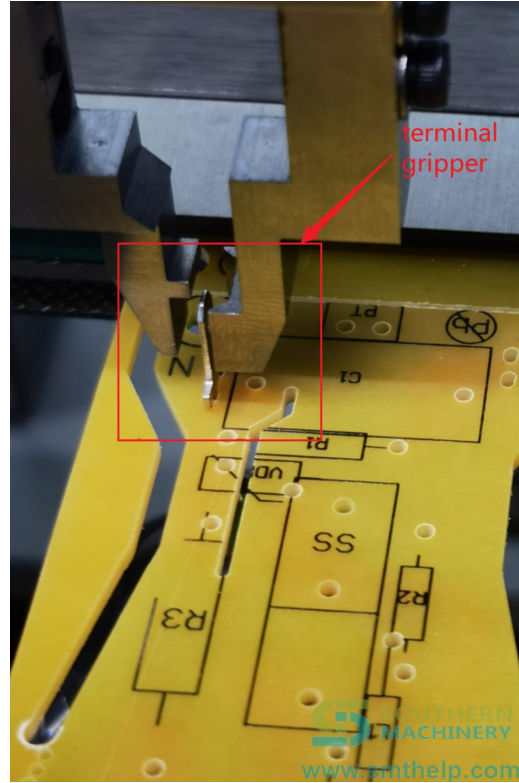
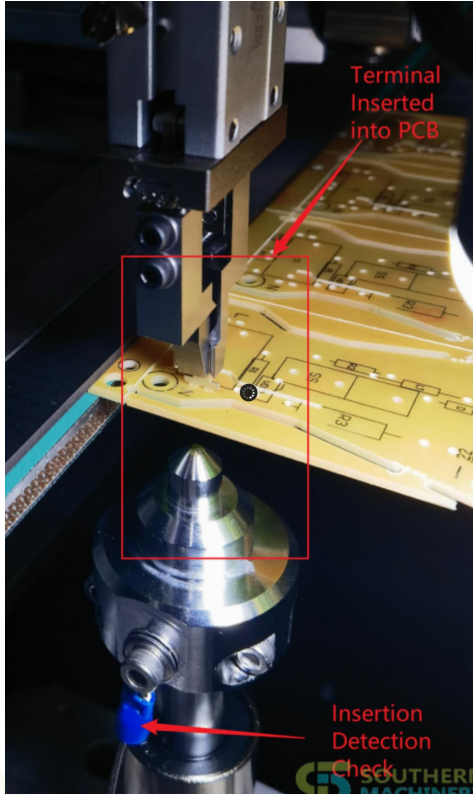

Equipment size	1700mm*1300mm*1600mm (2 heads)
Material packaging	Terminal in bulk package or reel package
Speed	12000 CPH
PCB size	380mm*280mm (enlarged size can be customized)
Number of insertion heads	2 insertion heads
terminal thickness	≥0.5mm ≤1.2mm
Vertical error	≤0.8°
PCB requirements	The insertion hole is 0.5±0.1mm larger than the component lead
Insertion angle	360°(increment 1°)
Body distance	The distance between the components ≥ 2mm
Clinch	Inward clinching/Outward clinching
Feeding system	Vibration Bowl Feeder/Reel feeder
Motion accuracy	0.001mm/pulse
Programming function	Online visual programming, visual correction, EXCEL
Data import	USB interface import, manual entry
Power	Single 220V/AC, 50/60HZ, 2KVA
Equipment weight	1200KG



S7020P

▶ Applicable components: **Pin**

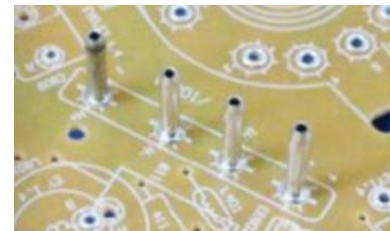

▶ 2 insertion heads and 2 reel feeder

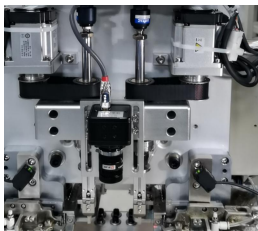

▶ Speed: **12000CPH**



S7020E



Applicable components: **Eyelet**



2 insertion heads and 2 bowl feeder

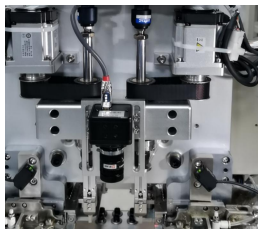

Speed: **12000CPH**



S7020S



Applicable components: **Tact Switch**

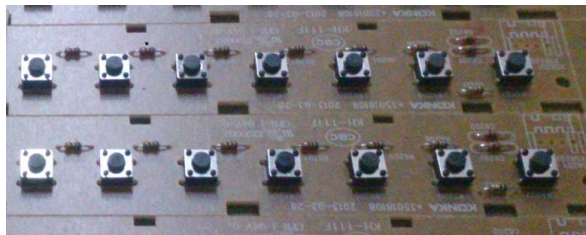

2 insertion heads and 2 bowl feeder

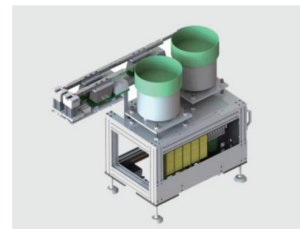
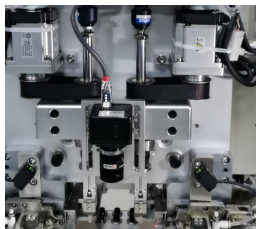

Speed: **12000CPH**

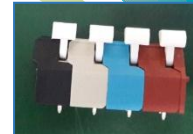

S7020F

▶ Applicable components: **Odd form components**

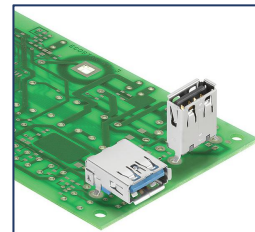

▶ 2 insertion heads and 2 reel feeder

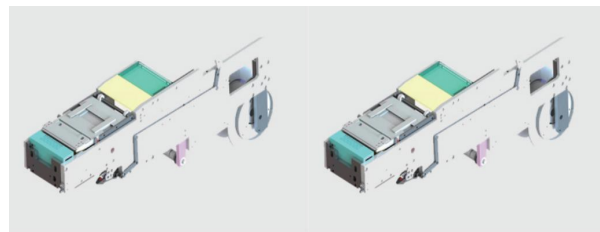
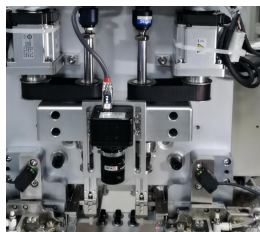

▶ Speed: **5000CPH**

Application industry

Home appliance

Car

Power

Digital watches

Electronic components, etc

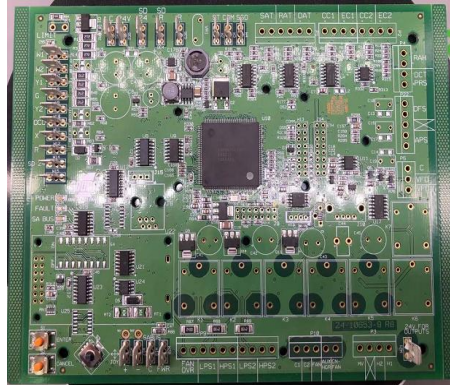
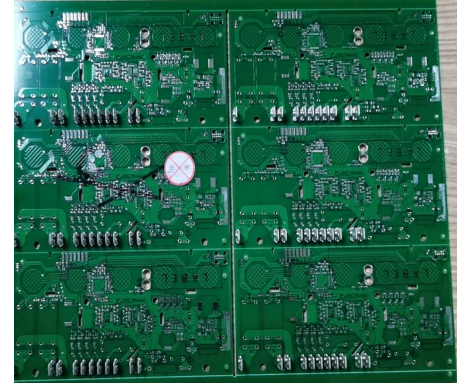
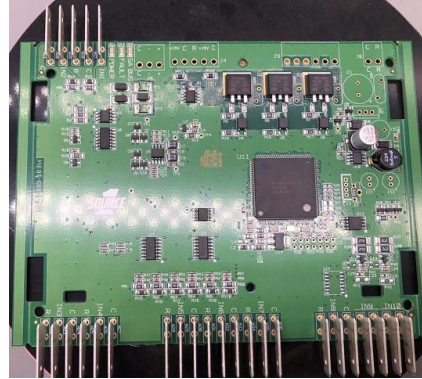

- [THT Odd form insertion machine working for Smart EMS factory PCB assembly](https://youtu.be/aOihpenVfNQ) :
<https://youtu.be/aOihpenVfNQ>
- [S7000T TE reel terminal insertion machine for Smart EMS factory PCB assembly](https://youtu.be/mi1Pf6ZfLWg) :
<https://youtu.be/mi1Pf6ZfLWg>
- [Automatically insert bulk FASTON Terminals's solution](https://youtu.be/XLjedTqB_k) :
https://youtu.be/XLjedTqB_k
- [2 heads Bulk or Reel PIN Eyelet Terminal Insertion Machine for Smart EMS factory PCB assembly](https://youtu.be/njBt_XLwvLI)
https://youtu.be/njBt_XLwvLI
- [High-speed automatic bulk/tape terminal insertion solution](https://youtu.be/OD8e-Wx5JcA) :
<https://youtu.be/OD8e-Wx5JcA>

[Machine 3D drawing:](http://file.autoinsertion.com/SMT%20machine%203D%20Drawing%20in%20Html/S-7020T_Terminal_insertion.html)

http://file.autoinsertion.com/SMT%20machine%203D%20Drawing%20in%20Html/S-7020T_Terminal_insertion.html



Working Video - Bulk Terminal Insertion



Please visit

www.smthelp.com

Find us more

<https://www.facebook.com/autoinsertion>

Know more our team

<https://cn.linkedin.com/in/smtsupplier>

Welcome to our factory in Shenzhen China

See more machine working video, please Youtube

[Auto Insertion](#)

Google

Auto+insertion, to get more informations

Looking forward to your email

info@smthelp.com